



Beautiful, Energy Efficient Garden Rooms

Specification Guide | Version 1.0 | April 2021

Gardenrooms
By Ultraframe

Introducing

The Studio and The Pavilion

Easy to build in just one day, Ultraframe Garden Rooms are designed with familiar components that exceed Building Regulations for thermal performance with U-Values as low as 0.16. Unlike cedar clad garden rooms, Ultraframe Garden Rooms won't fade over time, thanks to their unique premium contemporary grey finish.



Dimensions: The Studio 3 Walls 3600mm x 4800mm



Dimensions: The Pavilion Right Hand Corner 3600mm x 4800mm

Easy and fast to build

Garden Rooms from Ultraframe are built with familiar Ultraframe components and accompanied with a high quality installation guide to ensure your installation runs smoothly. We suggest using a pre-finished internal board like Fermacell on the interior to save you time on plastering. The wall panels are rapid to install thanks to the patented clip-fit mechanism.

High thermal performance

The components for an Ultraframe Garden Room are Building Regulation compliant for use in a home extension. In contrast, standard Garden Rooms are not required to reach this high level and will be more expensive to heat - they might even struggle to achieve a comfortable temperature in the colder months.

Available with or without fixed rooflights

Most Garden Rooms treat fixed rooflight integration as an 'extra' which adds cost to the build. Whether you design your Garden Room with fixed rooflights or not the price is the same. You'll only pay extra for the glass. Plus the shaped glazing in the roof adds a unique design element to The Pavilion.

Short lead times

Ultraframe Garden Rooms are precision engineered off site in a high capacity factory. This means your garden room can be delivered within 10 days of your order.

Longer life span

Made from conservatory and home extension quality products, Garden Rooms from Ultraframe stand the test of time. All components are guaranteed for 10 years by Ultraframe. Our Gardens Rooms are intended for use with grey claddings, whether you choose cement boards (e.g. Marley Cedar) or uPVC claddings, they are low maintenance and won't fade quickly like alternative timber claddings.

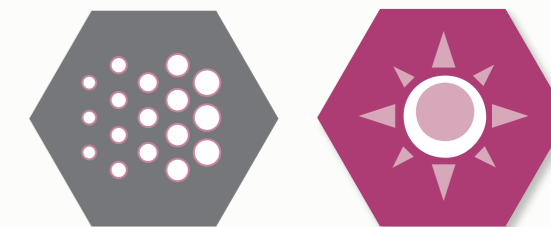

FADE FREE
Won't fade like cedar clad alternatives

BRIGHT
Cost effective, integrated rooflights

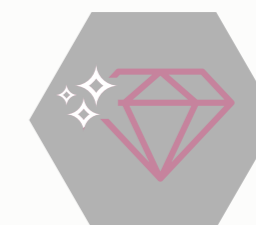

DURABLE
Building Regulation approved parts with a 30+ year life span

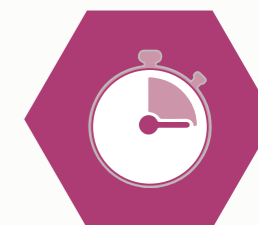

FAST
Available on a 10-day lead time, watertight in less than a day



ENERGY EFFICIENT
Twice the thermal performance of other premium garden rooms

| | Home Extension Building Regulation Requirement | Ultraframe Garden Room Performance | Competitor SIP Panel Garden Room Performance |
|-------|--|------------------------------------|--|
| Roof | 0.18 | 0.16 | *0.31 |
| Walls | 0.27 | 0.17 | *0.35 |

*U-Value measures the amount of heat able to escape. The lower the u-Value the more thermally efficient the room will be.

Contents

| | | | |
|----------------------------------|-----------|---------------------------------------|----|
| Provided by Ultraframe | 4 | Cladding Set-outs / Internal Boarding | 18 |
| Planning Permission | 5 | Electrics | 19 |
| The Studio | 6 | Lighting / Ventilation for Claddings | 20 |
| The Tall Studio | 8 | Window and Door Apertures | 21 |
| The Pavilion | 10 | Larger Door Spans | 22 |
| The Premium Pavilion | 12 | Maximum Door Spans | 23 |
| Specification guide | | Bases | 24 |
| Walls / Insulated Columns / Roof | 14/15 | How to Calculate Your Materials | 26 |
| Glass / Cill Dimensions | 16 | Order Form | 29 |
| Fasica / Claddings | 17 | | |

Provided by Ultraframe



Roof



Columns



Wall panels

Breathable membrane, plus vertical battens for easy cladding fixing



Fascia

Structural Support for large doors



Bi-fold Support Beam and Structural Goalposts



Glass

Conservaglass Standard Blue. (Can be supplied unglazed)

Not Provided By Ultraframe

- Plasterboard
- Doors
- Base
- Cills
- Claddings
- Windows
- Electrics

Planning Permission

Planning permission is not required providing that:

- If the edge is within 2m of a boundary the height does not exceed 2500mm
- The Garden Room is smaller than 25m²
- Once completed at least half the garden remains free from building structures including sheds
- On duo pitch roofs (The Pavilions) if the edge is more than 2m away from the boundary the eaves height is less than 2500mm and the entire height is less than 4000mm
- On single pitch roofs (The Studios) if the edge is more than 2m away from the boundary the entire height is less than 3000mm
- The Garden Room is stand alone (does not use an outbuilding for a host wall)

Additional rules apply for listed buildings, areas of outstanding natural beauty, conservation areas, world heritage sites, national parks and designated land. The studio has a height of 2500mm and does not need planning permission. All other designs may need planning permission if close to a boundary. All set sizes on Ultraframe Garden Rooms are under 25m² to comply with planning legislation.

For more information visit www.planningportal.gov.uk



The Studio



The Tall Studio



The Pavilion



The Premium Pavilion

| Garden Room Design | Planning Permission Required (Within 2m of the boundary) | Planning Permission Required (Beyond 2m of the boundary) |
|----------------------|--|--|
| The Studio | No | No |
| The Tall Studio | Yes | No |
| The Pavilion | Yes | No |
| The Premium Pavilion | Yes | No |

The Studio

Perfect for when the Garden Room may be located close to a boundary, The Studio is contemporary and compact. Our lowest cost option, The Studio's simple reverse lean-to design maximises the 2500mm height at the front and does not need planning permission.

Key Features

- Reverse lean-to roof (2.5° pitch) with 2 optional fixed rooflights.
- 2500mm maximum height (no planning permission required)
- 2 tier flat fascia – anthracite grey
- 4 corner columns clad in anthracite grey aluminium

Sizes

- Projection: 2400mm or 3600mm
- Width: 3600mm, 4200mm, 4800mm or 6000mm

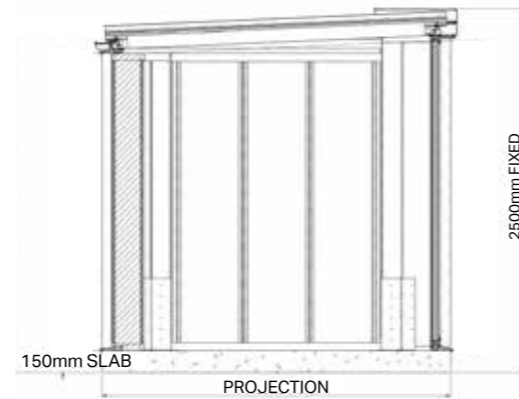

Design Options: There are 3 different design options on The Studio



Right hand corner
2 walls, full height glazing on left hand side, doors and windows to front



Left hand corner
2 walls, full height glazing on right hand side, doors and windows to front



3 full walls
Windows and doors to the front

Rooflights



Solid roof with no fixed rooflights



2 rectangular fixed rooflights
Supplied glazed or unglazed

Layouts

The right hand corner suggested layouts below are shown here with fixed rooflights. Please note the rooflight positions are fixed.

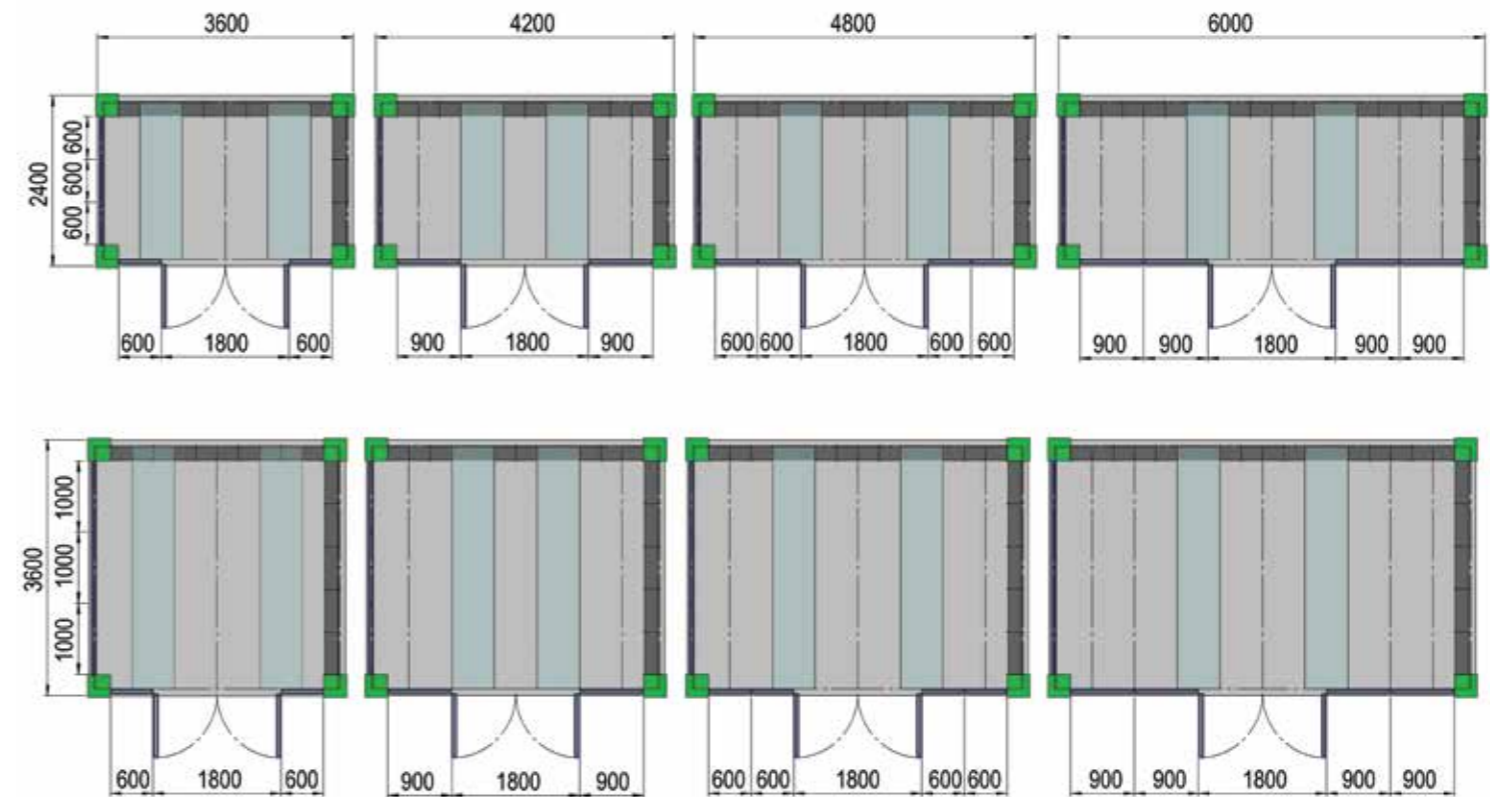

Key:

- Wall panels
- Fixed rooflights
- Insulated corner columns
- Glazed walls
- Insulated roof panels

The Tall Studio

The Tall Studio is contemporary and compact, but has extra room height if needed for added versatility, for example in a home gym. The Tall Studio's simple reverse lean-to design maxes out at 2900mm at the front.

Key Features

- Reverse lean-to roof (2.5° pitch) with 2 optional fixed rooflights
- 2900mm maximum height
- 2 tier flat fascia – anthracite grey
- 4 corner columns clad in anthracite grey aluminium

Sizes

- Projection: 2400mm or 3600mm
- Width: 3600mm, 4200mm, 4800mm or 6000mm



Design options: There are 3 different design options on The Tall Studio



Right hand corner
2 walls, full height glazing on left hand side, doors and windows to front



Left hand corner
2 walls, full height glazing on right hand side, doors and windows to front



3 full walls
Windows and doors to the front

Rooflights



Solid roof with no fixed rooflights



2 rectangular fixed rooflights
Supplied glazed or unglazed

Window Configuration shown is our preferred option, other configurations are possible.

Layouts

The right hand corner suggested layouts below are shown here with fixed rooflights. Please note the rooflight positions are fixed.

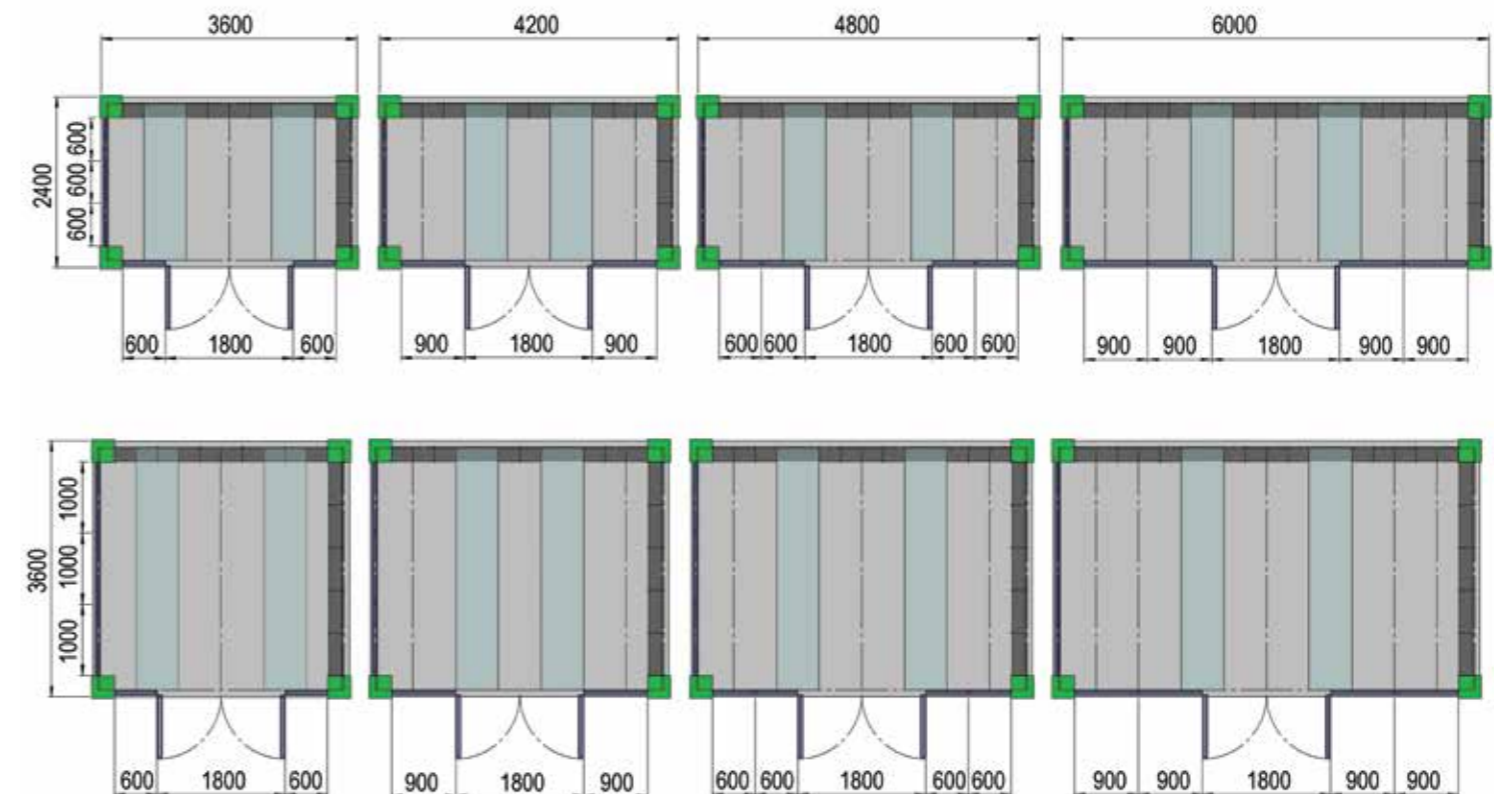

Key:

- Wall panels
- Fixed rooflights
- Insulated corner columns
- Glazed walls
- Insulated roof panels

The Pavilion

The Pavilion makes a more traditional statement with the look and feel of an orangery. Spacious in design, The Pavilion has the option for 4 fixed rooflights to bring more natural light to the Garden Room.

Key Features

- Double hipped Georgian roof with 4 optional fixed rooflights
- Fixed 25° pitch (except on 3600mm x 3600mm)
- 2 tier flat fascia – anthracite grey
- 4 corner columns clad in anthracite grey aluminium

Sizes

- Projection: 2400mm or 3600mm
- Width: 3600mm, 4200mm, 4800mm, 6000mm

Design options: There are 3 different design options for The Pavilion



Right hand corner
2 walls, full height glazing on left hand side, doors and windows to front



Left hand corner
2 walls, full height glazing on right hand side, doors and windows to front



3 full walls
Windows and doors to the front

Rooflights



Solid roof with no fixed rooflights



4 fixed rooflights
Supplied glazed or unglazed

Layouts

The right hand corner suggested layouts below are shown here with fixed rooflights. Please note the rooflight positions are fixed.

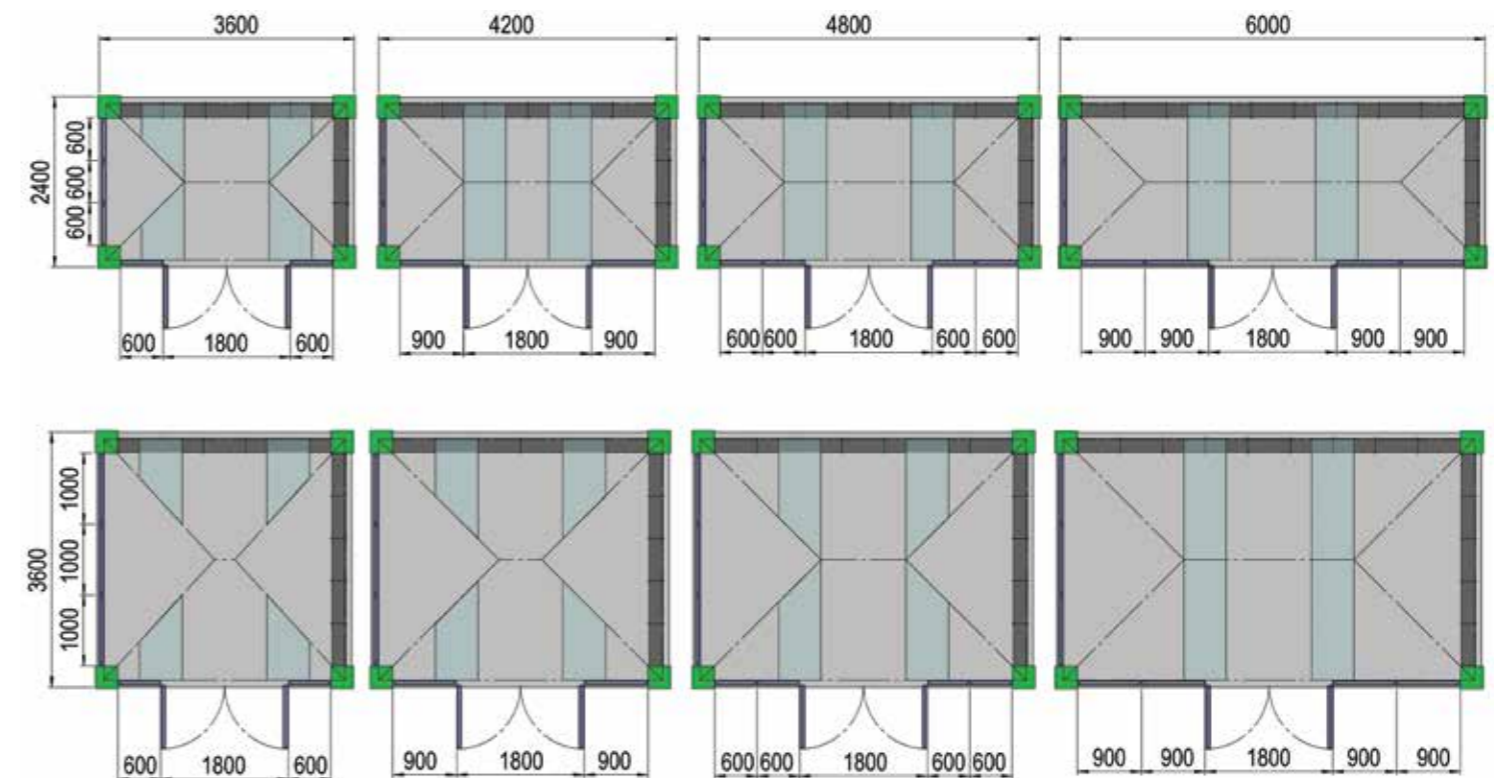

Key:

- Wall panels
- Fixed rooflights
- Insulated corner columns
- Glazed walls
- Insulated roof panels

The Premium Pavilion

Even more special than our standard Pavilion, the Premium Pavilion uses inline insulated columns to break up the side elevations with windows. These columns not only make a style statement but add thermal performance, ensuring The Pavilion retains heat really well even in cold temperatures.

Key Features

- Double hipped Georgian roof with 4 optional fixed rooflights
- Fixed 25 ° pitch (except on 3600mm x 3600mm)
- Inline columns and full height glazing on the sides (1 column per elevation on the 2400mm projection and 2 columns on the 3600 projection)
- 2 tier flat fascia – anthracite grey
- 4 corner columns clad in anthracite grey aluminium

Sizes

- Projection: 2400mm or 3600mm projection
- Width: 3600mm, 4200mm, 4800mm, 6000mm

Design options: There are 3 different design options on The Premium Pavilion



Right hand corner
2 walls, full height glazing with in line columns on left hand side, doors and windows to front



Left hand corner
2 Walls, full height glazing and in line columns on right hand side, doors and windows to front



1 full back wall
1 full back wall and 3 glazed walls, with inline columns to both sides

Rooflights



Solid roof with no fixed rooflights



4 fixed rooflights
Supplied glazed or unglazed

Layouts

The right hand corner suggested layouts below are shown here with fixed rooflights. Please note the rooflight positions are fixed.

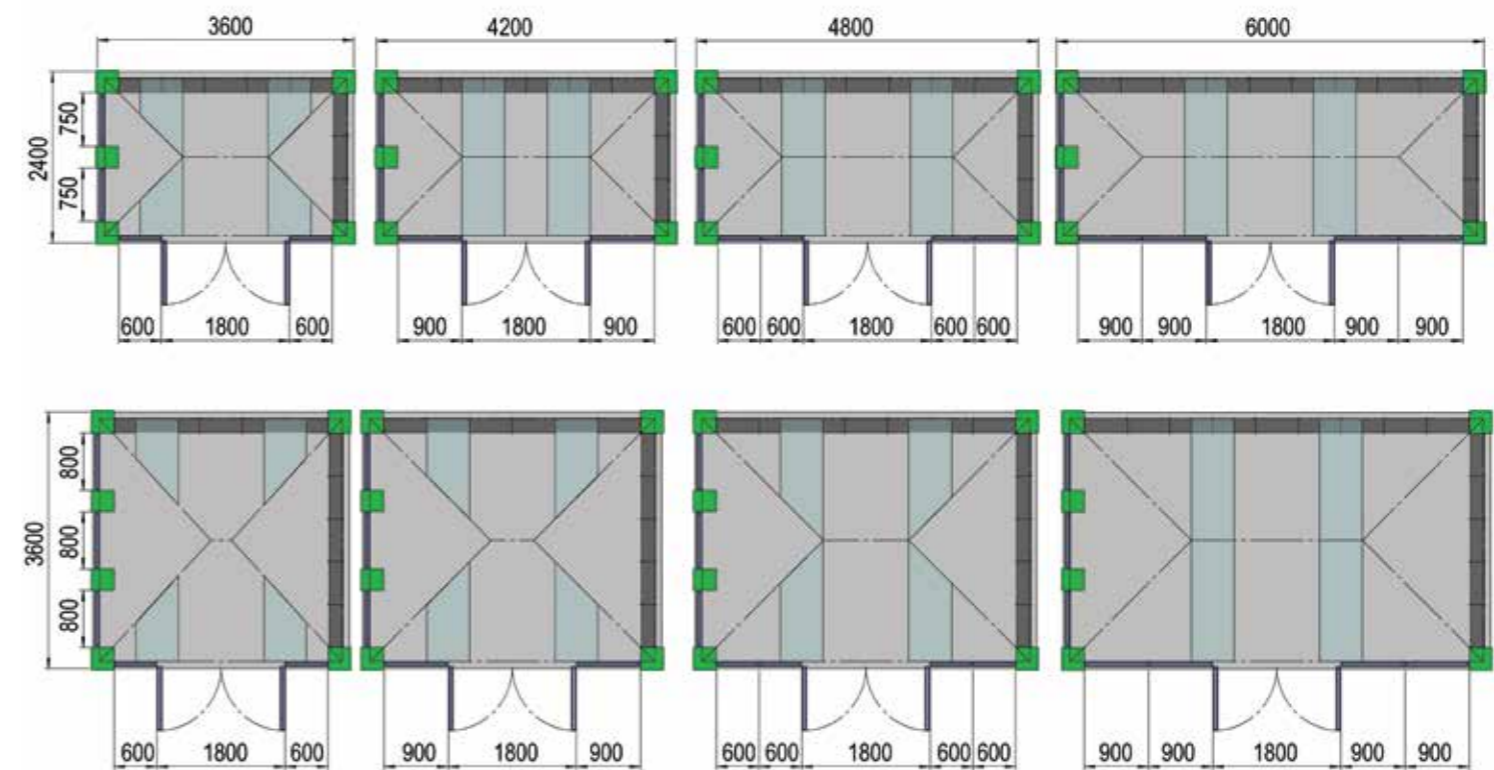

Key:

- Wall panels
- Glazed walls
- Fixed rooflights
- Insulated roof panel
- Insulated corner columns & insulated inline columns

Specification Guide

Walls

The Garden Room walls are made from Ultraframe's patented wall panels that deliver a U-Value of 0.17 which is the most energy efficient garden room wall on the market.

The unique hybrid design of structural insulation combined with an i-beam structure of galvanised steel and treated timber ensures the walls are both warm and structurally strong.

The wall panels easily slot into a floor tray which is screwed to the concrete pad. The wall panels are easily clipped together in minutes giving you a rapid Garden Room installation.

The walls are supplied with breathable membrane and battens ready for cladding.



Insulated columns

Engineered insulated corner columns give the Garden Room inner strength, solidity and warmth.

Internally the super-insulated core makes these columns 5 times more thermally efficient than similarly sized brick columns and externally they are powder coated in RAL 7016 anthracite grey to perfectly match the fascia.

The inline columns used on the sides of The Premium Pavilion create a style statement and improve energy efficiency too.

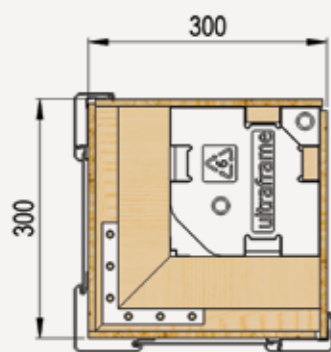

Corner column

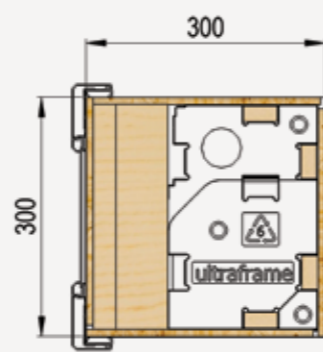

Inline columns – Premium Pavilion only

Roof

Our insulated solid roof is ideal for Garden Rooms. Externally, the roof is finished in RAL 7016 anthracite grey and glazed with insulated composite panels. Internally, it uses two separate insulation layers.

At the eaves on The Pavilion, the insulated internal pelmet engineered steelwork ladder system is used - all internal roof surfaces are then boarded (see page 18). The roof has an energy efficient U-Value of 0.16W/m2k.

The Studio

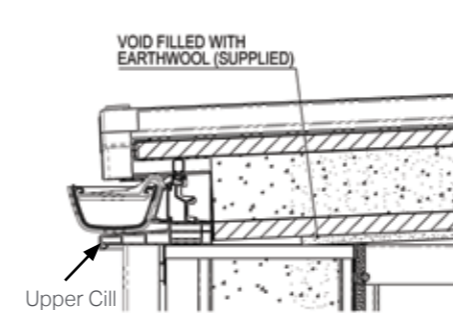

Rear wall to roof

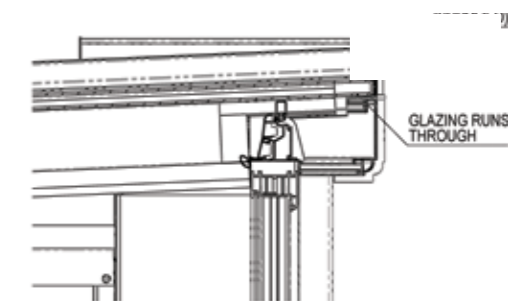

Front to fixed rooflights detail

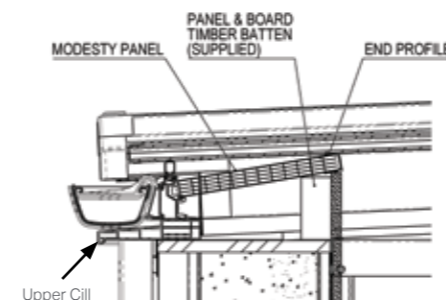

Rear wall to fixed rooflights

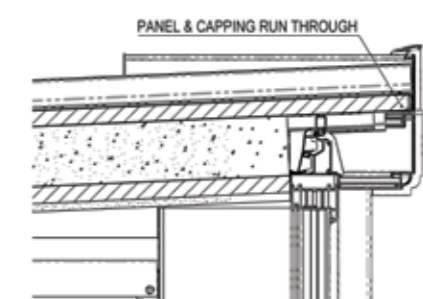

Front frame to roof

The Pavilion



Fixed rooflights to eaves beam

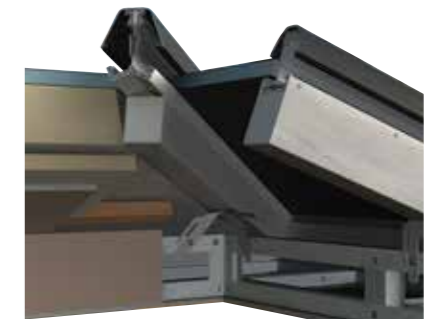

Hip to eaves beam

Glass

Ultraframe Garden Rooms with rooflights can be supplied with glass or unglazed.

Specification is as follows:

- U-Value 1.2
- Light transmission 42%
- Solar rejection 60%
- UV protection 83%
- Toughened to BS EN 12150-1
- Manufactured to BE EN 1279-2
- 10 year guarantee
- Self clean
- Argon cavity filled
- Warm edge spacer
- 24mm
- Blue

Glass Area (m²)

If you are supplying your own glass, the total area of glass is shown below to help you cost each project.

| Studio | 3600 | 4200 | 4800 | 6000 | Pavilions | 3600 | 4200 | 4800 | 6000 |
|--------|------|------|------|------|-----------|------|------|------|------|
| 2400 | 2.58 | 2.58 | 2.58 | 2.58 | 2400 | 2.10 | 2.88 | 2.88 | 2.88 |
| 3600 | 3.96 | 3.96 | 3.96 | 3.96 | 3600 | 3.19 | 3.62 | 3.62 | 4.40 |

Cill dimensions

A cill is required around the base of each Garden Room - we recommend 30mm x 150mm with welded corner joints and splits and jointers on the straight run. An upper cill is required for The Studio and The Tall Studio only. This is required on three sides (both side elevations plus the back wall).

| Cill Internal Dimensions | | | | | |
|--------------------------|-------|-----------------------------|---------------------|-------------------------------|---------------------|
| Projection | Width | The Studios & The Pavilions | | The Studios Only- Upper cills | |
| | | Internal Width | Internal Projection | Internal Width Upper | Internal Projection |
| 2400 | 3600 | 3402 | 2202 | 3402 | 2005 |
| | 4200 | 4002 | | 4002 | |
| | 4800 | 4602 | | 4602 | |
| | 6000 | 5802 | | 5802 | |
| 3600 | 3600 | 3402 | 3402 | 3402 | 3205 |
| | 4200 | 4002 | | 4002 | |
| | 4800 | 4602 | | 4602 | |
| | 6000 | 5802 | | 5802 | |

The Studios

Rear wall to roof

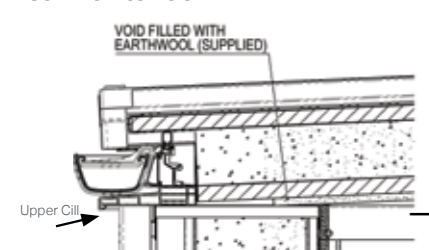

The Studios and The Pavilions

Lower wall detail

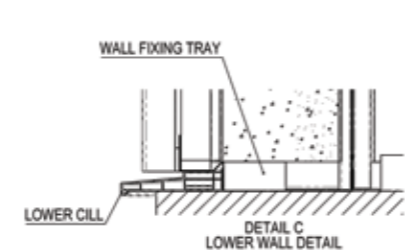

Cill details

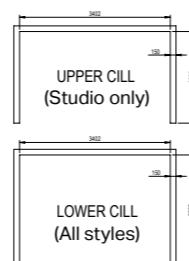

Total cill lengths: The tables below show the total length of cill required for each of the building types in mm. Please note the Studio dimensions include both the lower and upper cills.

| Total Studio Cill Length Required (M) includes upper cill | | | | |
|---|-------|-------|-------|-------|
| | 3600 | 4200 | 4800 | 6000 |
| 2400 | 18.62 | 20.42 | 22.22 | 25.82 |
| 3600 | 23.42 | 25.22 | 27.02 | 30.62 |

| Total Pavilion Cill Length Required (M) | | | | |
|---|-------|-------|-------|-------|
| | 3600 | 4200 | 4800 | 6000 |
| 2400 | 11.21 | 12.41 | 13.61 | 16.01 |
| 3600 | 13.61 | 14.81 | 16.01 | 18.41 |

Fascia

The 2 tier flat fascia hides end caps to give the roofline a neat finish. Aluminium and powder coated in RAL 7016 anthracite grey, the fascia matches the insulated columns and roof perfectly.



2 tier flat fascia

Claddings

Whilst Ultraframe doesn't provide claddings, the wall panel is compatible with many cladding options available on the market.

We recommend that you use RAL 7016 anthracite grey external claddings to match our anthracite grey finish. We found the Marley Cedral® claddings in Slate Grey to be a great match. Each Marley Cedral Cladding board is 190mm x 3600mm.



Cedral lap

Wall prepared for cladding - battens supplied.

External cladding dimensions

For each elevation the dimensions of the area to be cladded are shown below:

The Studios

| Elevation Length | External Cladding Area on Each Elevation | | | | | |
|------------------|--|-----------|-----------|-----------------|-----------|-----------|
| | The Studio | | | The Tall Studio | | |
| | Width | 2400 proj | 3600 proj | Width | 2400 proj | 3600 proj |
| | Height | | | Height | | |
| 2400 | 1792 | 2010 | 1958 | 1792 | 2390 | 2338 |
| 3600 | 2992 | | | 2992 | | |
| 4200 | 3592 | | | 3592 | | |
| 4800 | 4192 | | | 4192 | | |
| 6000 | 5392 | | | 5392 | | |

The Pavilions

| Elevation Length | External Cladding Area | |
|------------------|------------------------|------------|
| | The Pavilion | |
| | Width | Height |
| 2400 | 1792 | 2400 Width |
| 3600 | 2992 | 2139 |
| 4200 | 3592 | |
| 4800 | 4192 | |
| 6000 | 5392 | |

Total areas (m²) needed to be covered by external claddings

The external cladding area of each Garden room design has been calculated for you below:

| Small Studio 2 walls | | | | |
|----------------------|-------|-------|-------|-------|
| | 3600 | 4200 | 4800 | 6000 |
| 2400 | 9.62 | 10.82 | 12.03 | 14.44 |
| 3600 | 11.87 | 12.89 | 14.07 | 16.42 |

| Small Studio 3 walls | | | | |
|----------------------|-------|-------|-------|-------|
| | 3600 | 4200 | 4800 | 6000 |
| 2400 | 13.22 | 14.42 | 15.63 | 18.04 |
| 3600 | 17.58 | 18.75 | 19.92 | 22.27 |

| Tall Studio 2 walls | | | | |
|---------------------|-------|-------|-------|-------|
| | 3600 | 4200 | 4800 | 6000 |
| 2400 | 11.43 | 12.87 | 14.30 | 17.17 |
| 3600 | 13.99 | 15.39 | 16.80 | 19.60 |

| Tall Studio 3 walls | | | | |
|---------------------|-------|-------|-------|-------|
| | 3600 | 4200 | 4800 | 6000 |
| 2400 | 15.72 | 17.15 | 18.58 | 21.45 |
| 3600 | 20.99 | 22.39 | 23.79 | 26.60 |

| Pavilion 2 walls | | | | |
|------------------|-------|-------|-------|-------|
| | 3600 | 4200 | 4800 | 6000 |
| 2400 | 10.23 | 11.52 | 12.80 | 15.37 |
| 3600 | 12.80 | 14.08 | 15.37 | 17.93 |

| Pavilion 3 walls | | | | |
|------------------|-------|-------|-------|-------|
| | 3600 | 4200 | 4800 | 6000 |
| 2400 | 14.07 | 15.35 | 16.63 | 19.20 |
| 3600 | 19.20 | 20.48 | 21.77 | 24.33 |

| Premium Pavilion 2 walls | | | | |
|--------------------------|-------|-------|-------|-------|
| | 3600 | 4200 | 4800 | 6000 |
| 2400 | 10.23 | 11.52 | 12.80 | 15.37 |
| 3600 | 12.80 | 14.08 | 15.37 | 17.93 |

| Premium Pavilion Back wall only | | | | |
|---------------------------------|------|------|------|-------|
| | 3600 | 4200 | 4800 | 6000 |
| 2400 | 6.40 | 7.68 | 8.97 | 11.53 |
| 3600 | 6.40 | 7.68 | 8.97 | 11.53 |

The m² areas above are areas to be covered only and do not include a waste factor.

Cladding Set-outs

The diagram to the right shows the layout of the columns and battens so you can see how your own claddings will look relative to the column claddings.

Claddings must be between 10mm and 53mm in thickness.

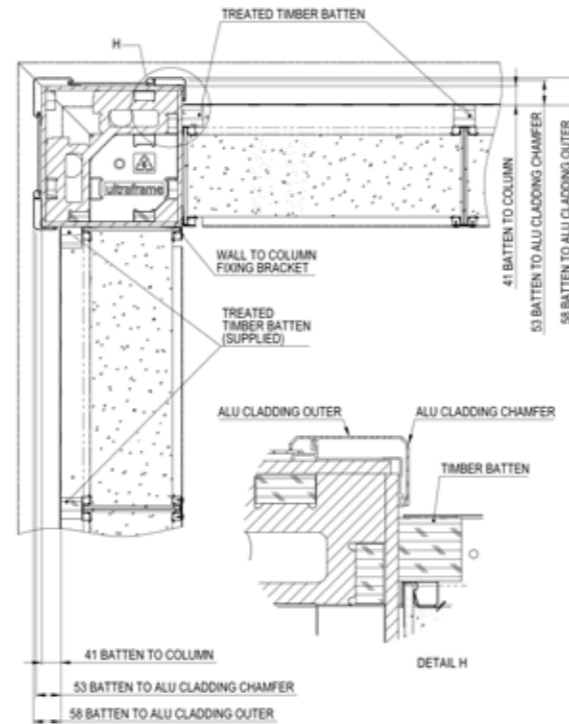

Internal boarding

We recommend you avoid plastering if possible to help prevent any damp issues if the room is left unheated.

We found that fermacell offers a good dry lining alternative solution that minimises wet trades on site, increases design flexibility and speeds up the build time.

Areas (m² needed to be covered by internal board)

The Studio

| | 3600 | 4200 | 4800 | 6000 |
|------|------|------|------|------|
| 2400 | 15 | 16 | 17 | 20 |
| 3600 | 24 | 26 | 28 | 32 |

| | 3600 | 4200 | 4800 | 6000 |
|------|------|------|------|------|
| 2400 | 21 | 23 | 26 | 31 |
| 3600 | 30 | 33 | 36 | 43 |

The Studio - left or right hand corner

The Small Studio - 3 walls

The Tall Studio

| | 3600 | 4200 | 4800 | 6000 |
|------|------|------|------|------|
| 2400 | 16 | 18 | 18 | 21 |
| 3600 | 26 | 28 | 30 | 34 |

| | 3600 | 4200 | 4800 | 6000 |
|------|------|------|------|------|
| 2400 | 23 | 26 | 29 | 34 |
| 3600 | 33 | 37 | 40 | 47 |

The Tall Studio - left or right hand corner

The Tall Studio - 3 walls

The Pavilion

| | 3600 | 4200 | 4800 | 6000 |
|------|------|------|------|------|
| 2400 | 20 | 40 | 40 | 40 |
| 3600 | 30 | 40 | 40 | 40 |

| | 3600 | 4200 | 4800 | 6000 |
|------|------|------|------|------|
| 2400 | 30 | 50 | 50 | 50 |
| 3600 | 30 | 50 | 50 | 50 |

The Pavilion - left or right hand corner

The Pavilion - 3 walls

The Premium Pavilion

| | 3600 | 4200 | 4800 | 6000 |
|------|------|------|------|------|
| 2400 | 20 | 40 | 40 | 40 |
| 3600 | 30 | 40 | 40 | 40 |

| | 3600 | 4200 | 4800 | 6000 |
|------|------|------|------|------|
| 2400 | 10 | 20 | 20 | 20 |
| 3600 | 10 | 20 | 20 | 20 |

The Premium Pavilion - left or right hand corner

The Premium Pavilion - Back wall

The above areas are the areas to be covered rounded up to the nearest square metre and do not include any additional waste factor

Electrics

We recommend that you run cable up through columns and along the top of the wall, do this as a first fit. **The cable needs to run in conduit, you must not let cabling come into direct contact with the EPS.** The conduit is readily available from any builders merchant. Consult and use a qualified "Part P" electrician prior to attempting electrical installations.

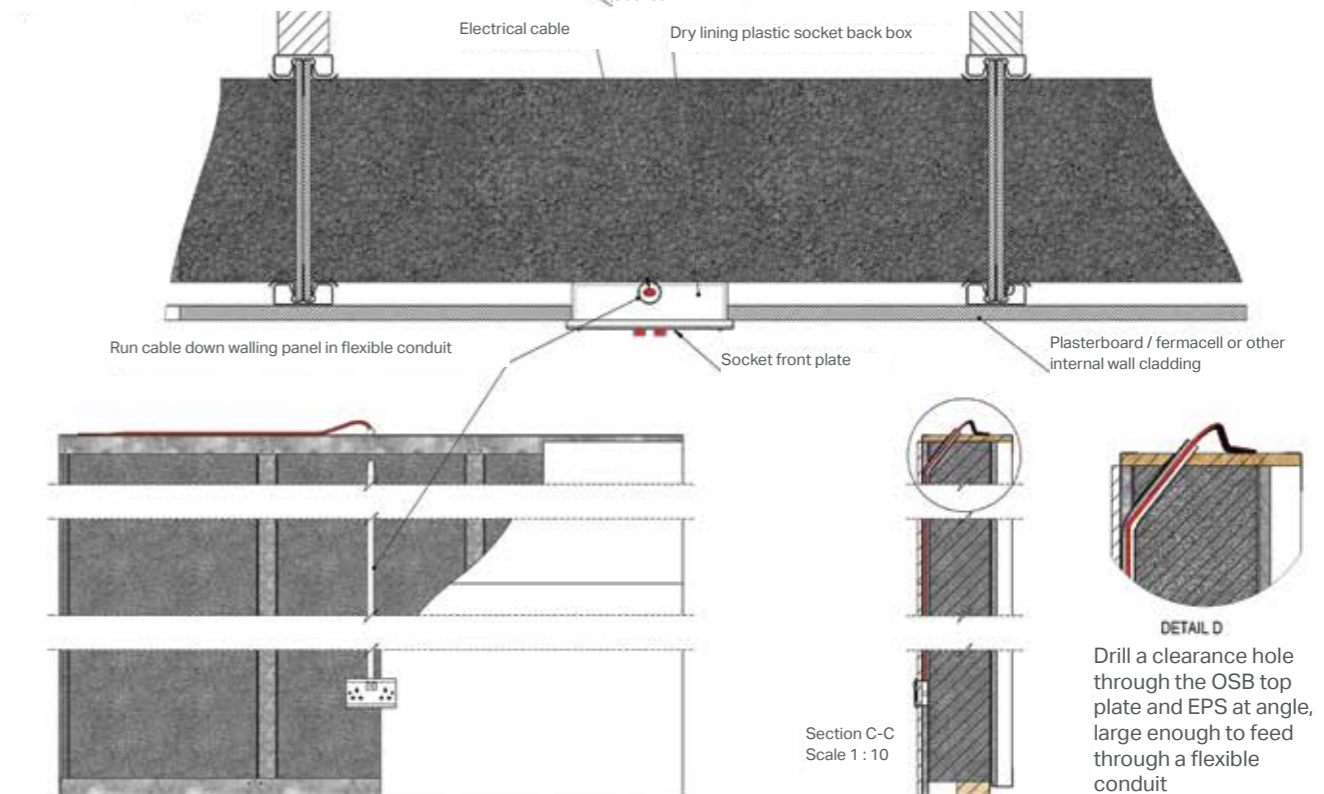
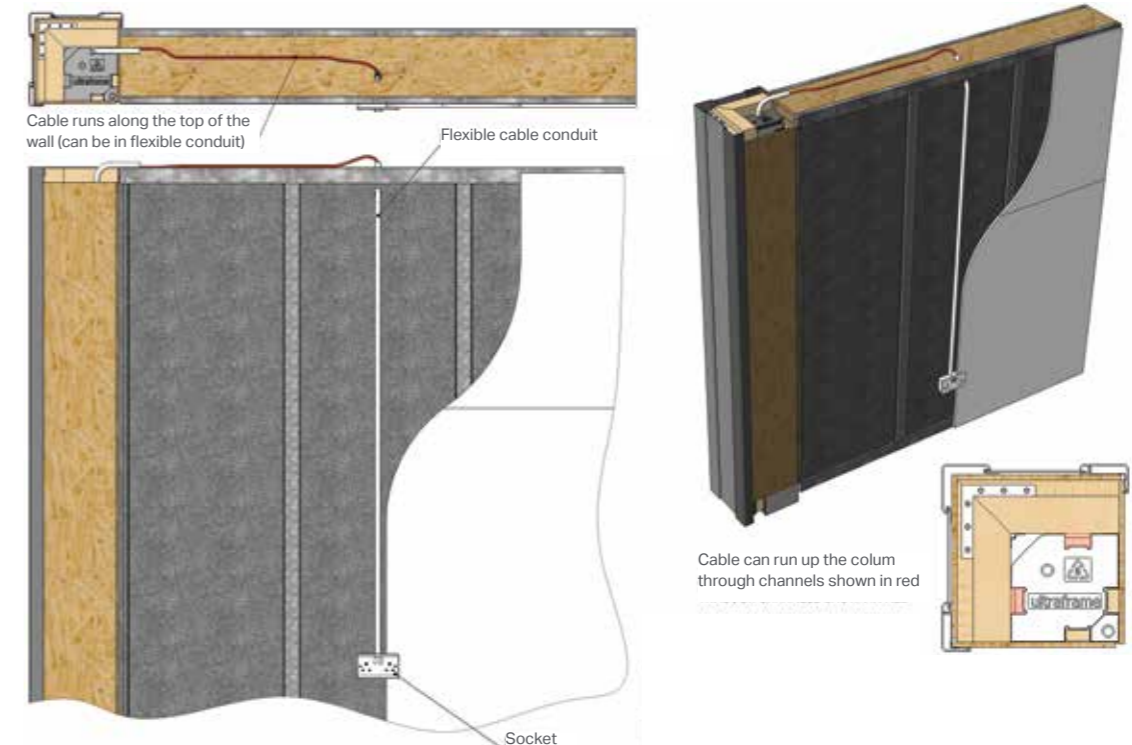

DISCLAIMER: WIRING PVC SHEATHING SHOULD NOT COME INTO CONTACT WITH THE EPS. RUN WIRING INSIDE CONDUIT TO PREVENT CONTACT.

Lighting

We always recommend that electrics and cabling are run in a flexible conduit, you must not let cabling come into direct contact with the EPS or roof insulation. The first fix cabling can be run into the Garden Room and along the top of the wall (as shown on page 19) and then directed to the location of the required light up the sides of the roof bars with enough cable to access through the internal boarding once fitted. Low energy and low heat lighting is recommended.

The Studio

We recommend slim surface mounted LED lights, wall mounted up/down lighters or perimeter channel LED light strips. Determine the location of the lights before the insulation is fitted. The cabling, which must be in flexible conduit and not come into contact with the insulation, should run along the top of the wall and up the bars adjacent to where the light will be fitted.



The Pavilion

We recommend that low energy, low heat LED lighting is fitted in the internal pelmet or the internal ridge board, or surface mounted fittings on either the ceiling or walls. In all circumstances consult and use a qualified "Part P" electrician prior to fitting your chosen light fittings and sockets.



Ventilation for Claddings

The diagram below explains how the wall panels are designed to allow sufficient airflow around claddings.

You will need to refer to your cladding technical guide for the ventilation requirements specific to the claddings which you are using.

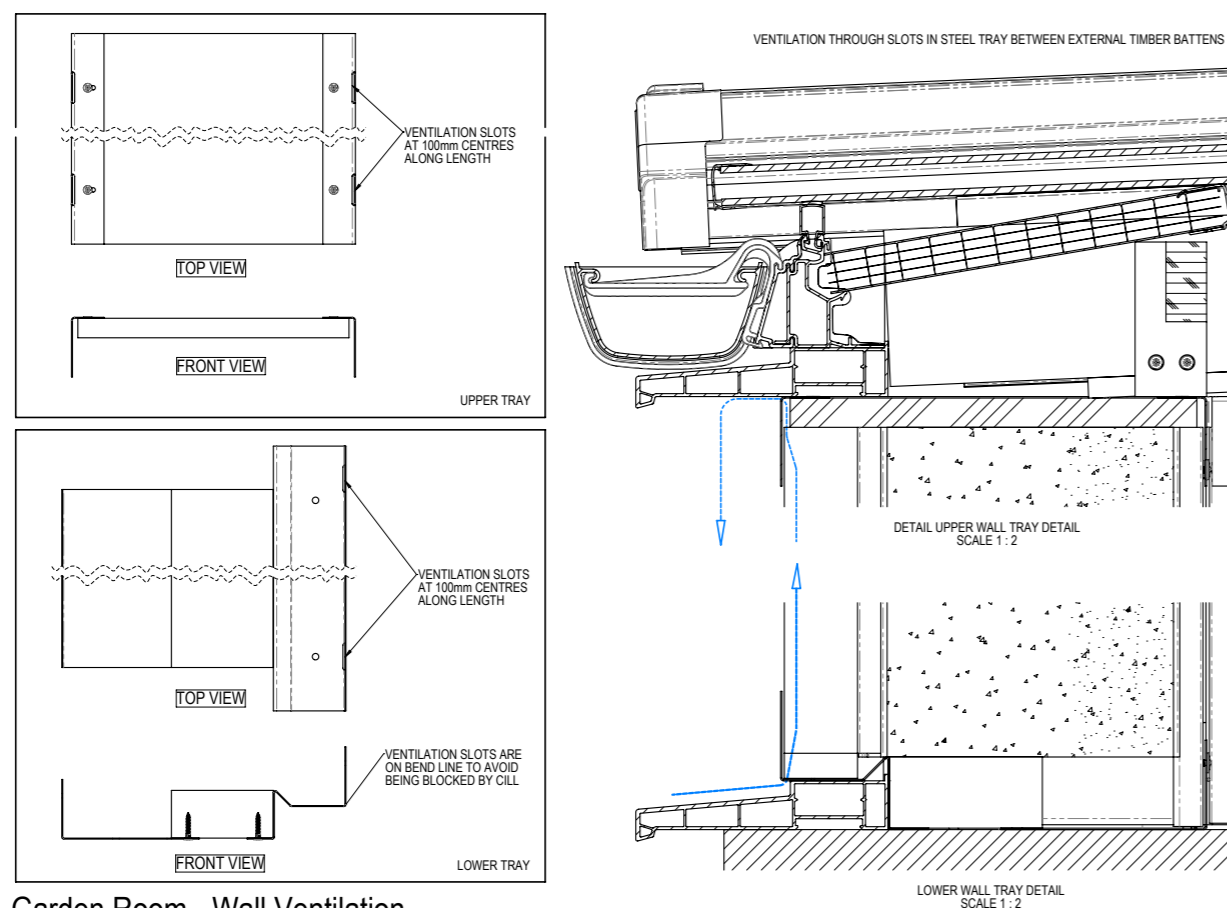

Garden Room - Wall Ventilation (Studio Garden Room Shown, the same detail applies to Pavilion)

Window and Door Apertures

This section helps you design your window and door layout and order the right size frames. The diagrams below show the aperture layout where you can place your windows and doors.

The aperture inside the columns is 600mm narrower than the base size on each elevation because each column is 300mm wide and this has been deducted. These numbers include a 6mm deduction in the height to allow for frame size tolerances, ensure good coverage from the corner column claddings. The upper cill (on Studios only) is considered part of the roof and sits above this aperture.

Window Frame Aperture Layout

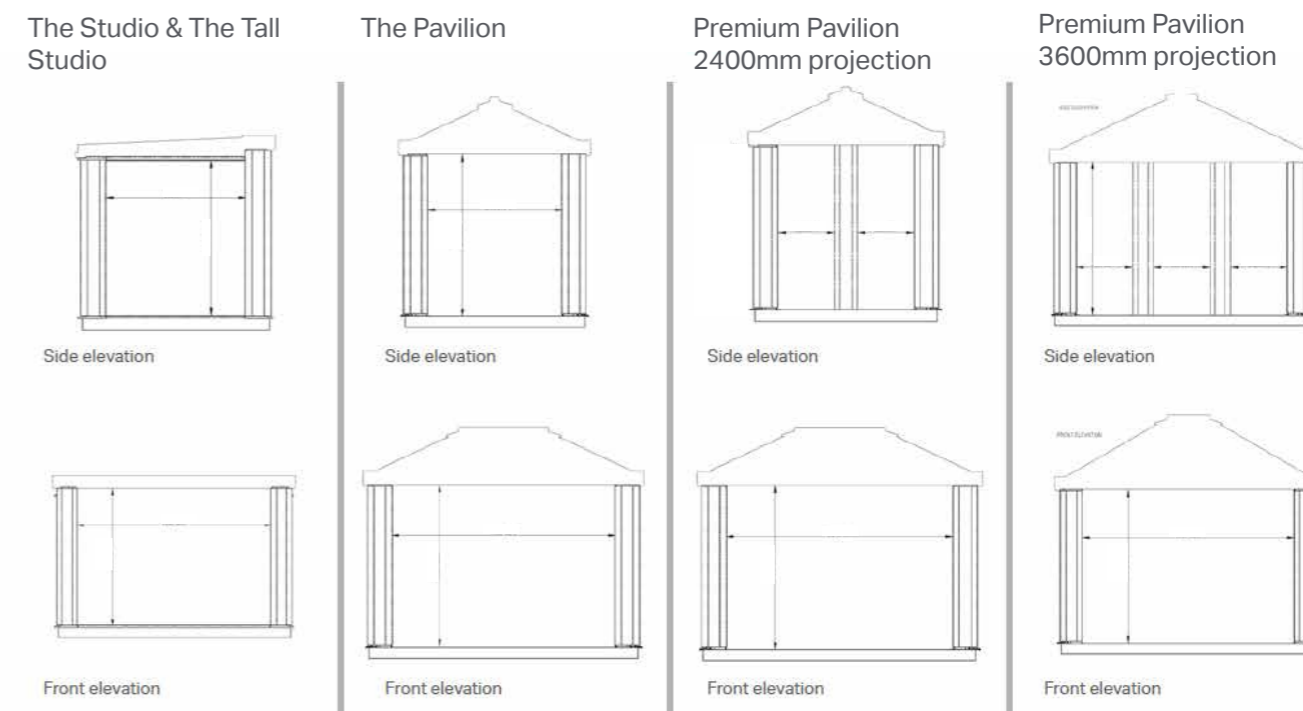

| Projection | Width | The Studio | | | | The Tall Studio | | | | The Pavilion | | | | The Pavilion Premium |
|------------|-------|-----------------|-------|----------------|-------|-----------------|-------|----------------|-------|-----------------|-------|----------------|-------|------------------------------|
| | | Front Elevation | | Side Elevation | | Front Elevation | | Side Elevation | | Front Elevation | | Side Elevation | | Side Elevation |
| | | Height | Width | Height | Width | Height | Width | Height | Width | Height | Width | Height | Width | Width Between Inline Columns |
| 2400 | 3600 | 2170 | 3000 | 2040 | 1800 | 2550 | 3000 | 2420 | 1800 | 2170 | 3000 | 1800 | 750 | |
| | 4200 | | 3600 | | | | | | | | | | | |
| | 4800 | | 4200 | | | | | | | | | | | |
| | 6000 | | 5400 | | | | | | | | | | | |
| 3600 | 3600 | 2170 | 3000 | 1989 | 3000 | 2550 | 3000 | 2369 | 3000 | 2170 | 3000 | 3000 | 800 | |
| | 4200 | | 3600 | | | | | | | | | | | |
| | 4800 | | 4200 | | | | | | | | | | | |
| | 5400 | | 5400 | | | | | | | | | | | |

These aperture sizes include a 6mm deduction to allow for tolerances.

Further deductions are required to determine your frame sizes as outlined below. Details of the eaves support beam and goalposts can be found on page 22. The goalpost cross beam depth is either 171mm or 201mm depending on which size and style of Garden room you choose.

| Deduction | Height (mm) | Width (mm) |
|--|-------------|------------|
| Lower cill (30mm x 150mm recommended) | 30 | 0 |
| Eaves Support Beam (front elevation only) | 70 | 0 |
| Goalpost (runs inside columns and below eaves) | *171/201 | 106 |

* See page 22-23 to determine which size goalpost is required

Large Door Spans

If you wish to design bi-folds or sliding doors into an Ultraframe Garden Room, lateral stability risks and structural support must be considered.

Unless using a goalpost (which can be supplied by Ultraframe) 500mm windows on either side of each corner column must be always used to avoid any lateral stability issues.

Sliding doors can be used on both the side and the front elevation, however an eaves support beam must be used on the front elevation to take the extra load. All sliding doors must have a reinforced mullion to support the roof load with glass in the fixed pane that is packed sufficiently to ensure the glass fits snugly top and bottom to create a solid element.

Bi-folding doors can be used, but will require a goalpost on both side and front elevations to manage lateral stability and support the load.

Eaves Support Beam



Studio

Pavilion

When using sliding or smaller bi-fold doors on the front elevation an Eaves Support Beam must be used. This runs along the entire width of the elevation and can be supplied with grey or white internal claddings. The beam is 70mm deep and so this must be deducted from the window and door heights at the front (see page 21). If you wish to match this frame line on the sides of the Pavilion a 70mm packer can be used and frame height reduced.

The Eaves Beam Support is only suitable for use on the front elevation.

Structural Goalposts

Structural goalposts are needed when using large bi-folding doors both to support the roof and to avoid any lateral stability issues.

The maximum unsupported span of the structural goalpost is however shorter than the aperture width on 6000mm wide Garden Rooms. In this case a 4 legged goalpost can be used where the intermediate legs sit behind doors and windows, equidistant from the centre.

2 legged goalpost

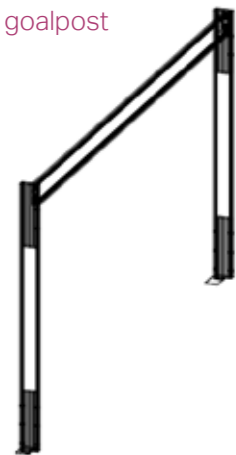

4 legged goalpost



The main vertical goalpost legs are 53mm wide each so a deduction of 106mm must be made for window/door widths. Intermediate legs (6000mm width only) do not require a deduction as they sit behind the door frame, however a deduction may be required for the chosen frame coupler. The depth of the goalpost cross beam varies depending on the size and style of garden room outlined below. These dimensions must be deducted from the window and door sizes shown on page 21.

| Studio | 3600 | 4200 | 4800 | 6000 |
|--------|------|------|------|------|
| 2400 | 171 | 171 | 201 | 201 |
| 3600 | 171 | 201 | 201 | 201 |

| Pavilion | 3600 | 4200 | 4800 | 6000 |
|----------|------|------|------|------|
| 2400 | 171 | 171 | 201 | 201 |
| 3600 | 171 | 171 | 201 | 201 |

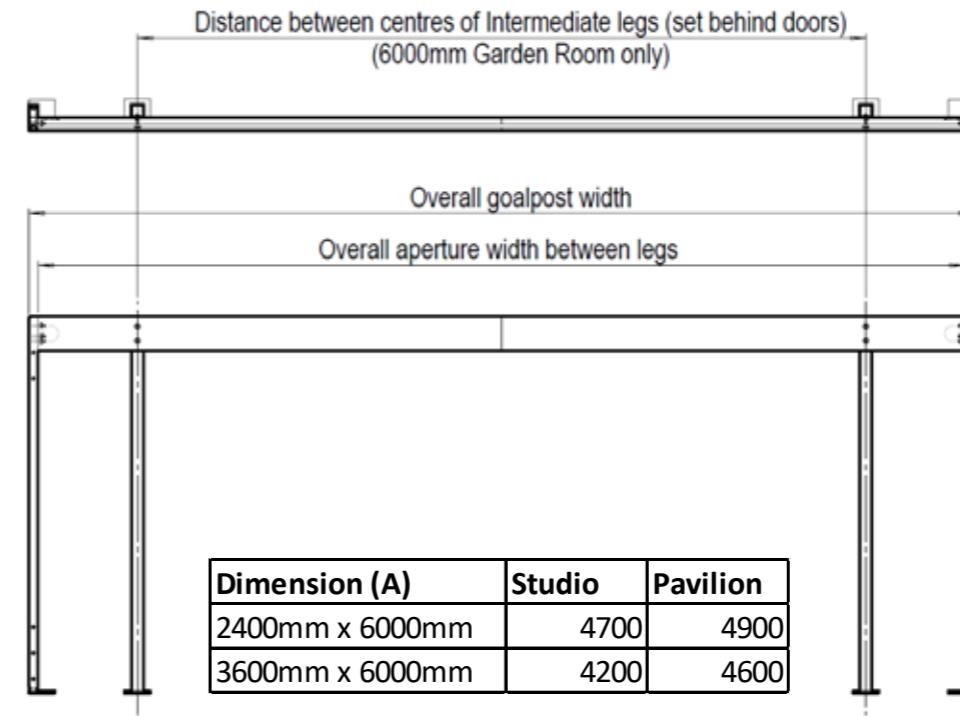

The 4 legged goalpost on the 6000mm wide garden rooms is designed with the intermediate legs centralised over the maximum span possible with this goalpost. This maximum span varies by Garden room design and is dimension (A) as outlined in the table below

Maximum Door Spans

The maximum allowable door span on each elevation is dependent on the maximum span of the eaves beam or goalpost, the deductions taken for columns, goalposts and the 500mm windows required (to avoid lateral stability issues) either side of the corner columns which are required on all garden rooms unless using a goalpost.

| Front Elevation - Maximum Openings (Door spans in mm) | | | | | | |
|---|--------|------------------------------------|---------------|--------------------------------|--------------------------------|--|
| Garden Room Base Size | | Frame sizes after column deduction | Standard | With Bi-fold support | | Goalpost |
| Projection | pWidth | Total Aperture length | Max Door Span | Max Door Span (5mm deflection) | Max Door Span (7mm deflection) | Max Door Span after 106mm deduction for vertical posts. (tight size) |
| 2400 | 3600 | 3000 | 1800 | 2000 | 2000 | 2894 |
| 2400 | 4200 | 3600 | 1800 | 2600 | 2600 | 3494 |
| 2400 | 4800 | 4200 | 1800 | 3080 | 3200 | 4094 |
| 2400 | 6000 | 5400 | 1800 | 3080 | 3351 | 4700 (Studio) 4900 (Pavilion)* |
| 3600 | 3600 | 3000 | 1800 | 2000 | 2000 | 2894 |
| 3600 | 4200 | 3600 | 1800 | 2600 | 2600 | 3494 |
| 3600 | 4800 | 4200 | 1800 | 2780 | 3028 | 4094 |
| 3600 | 6000 | 5400 | 1800 | 2780 | 3028 | 4200 (Studio) 4600 (Pavilion)* |

The table below shows the maximum possible doors sizes on each side elevation.

| Door Options on Side Elevation (maximum spans in mm) | | | |
|--|---|--|---|
| Projection | Standard (needs 500mm windows at corners for lateral stability) | 2 pane slider (can fill entire aperture) | Bi-folds with goalpost (can fill entire aperture) |
| 2400 | 800 | 1800 | 1694 |
| 3600 | 2000 | 3000 | 2894 |

Bases

We recommend a 150mm insulated slab in order to avoid rising damp from the ground and ensure a solid foundation for the Garden Room. 150mm has been selected so that the overall height of The Studio does not exceed the 2500mm height required to avoid planning permission.

The timber formwork is a temporary shuttering into which the concrete is poured. Once the concrete has set, the formwork is removed. The sequence for the base is as follows:

1. Excavate the area slightly larger than the Garden Room overall sizes.
2. Build timber formwork to the size of the Garden Room (inside dimensions of formwork), ensuring square (check diagonals).
3. If insulating around perimeter of slab, take the insulation thickness into consideration for the overall size.
4. Fill the base of the foundation with hardcore and compact.
5. Add a layer of sand and compact. Fit DPC to cover the area and lap up the sides of the formwork.
6. Insert 50mm sheet insulation.
7. Pour C20 concrete raft (depending on area an A142 steel mesh will be required)
8. Once fully set, the Garden Room installation can be carried out.

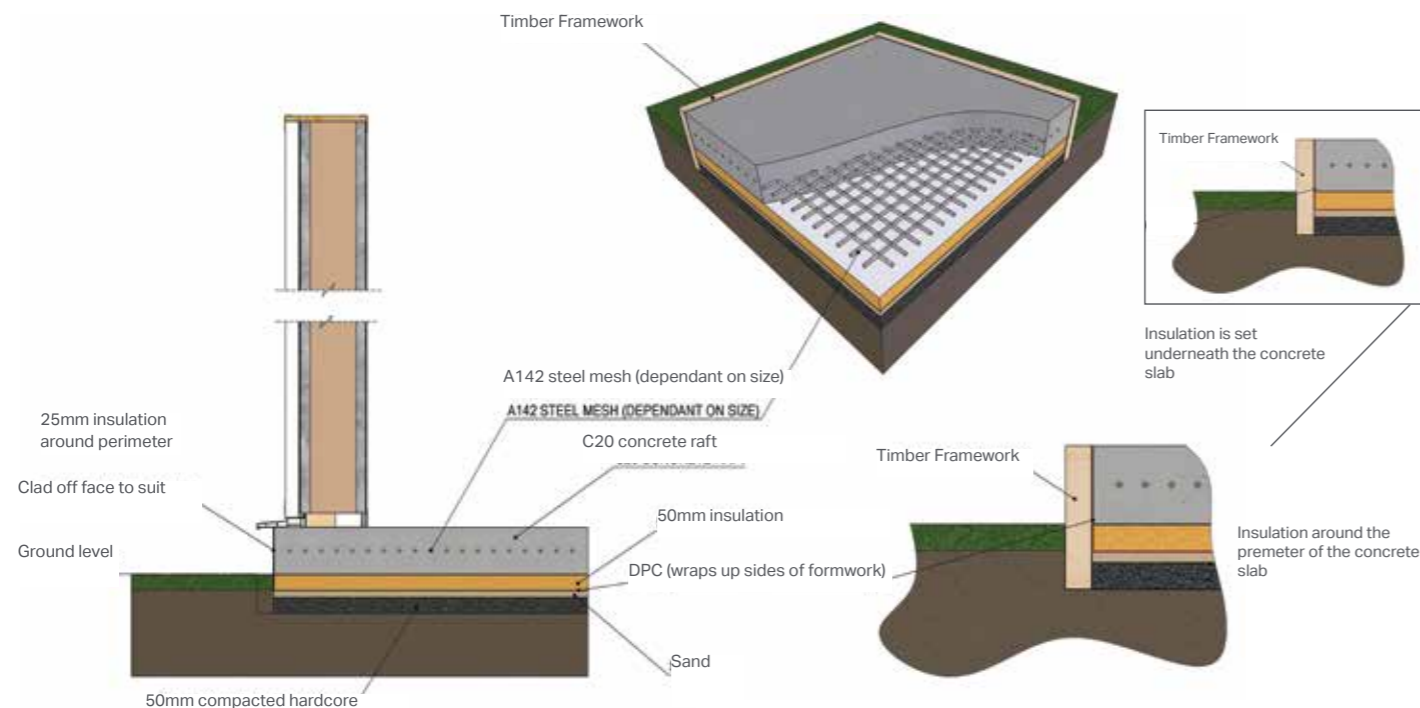

Bases

External Base Size

| | | | |
|-----------------|-----------------|-----------------|-----------------|
| 2400mm x 3600mm | 2400mm x 4200mm | 2400mm x 4800mm | 2400mm x 6000mm |
| 3600mm x 3600mm | 3600mm x 4200mm | 3600mm x 4800mm | 3600mm x 6000mm |

Internal Floor Size

| | | | |
|-----------------|-----------------|-----------------|-----------------|
| 1800mm x 3000mm | 1800mm x 3600mm | 1800mm x 4200mm | 1800mm x 5400mm |
| 3000mm x 3000mm | 3000mm x 3600mm | 3000mm x 4200mm | 3000mm x 5400mm |

Base plan 2400mm projection

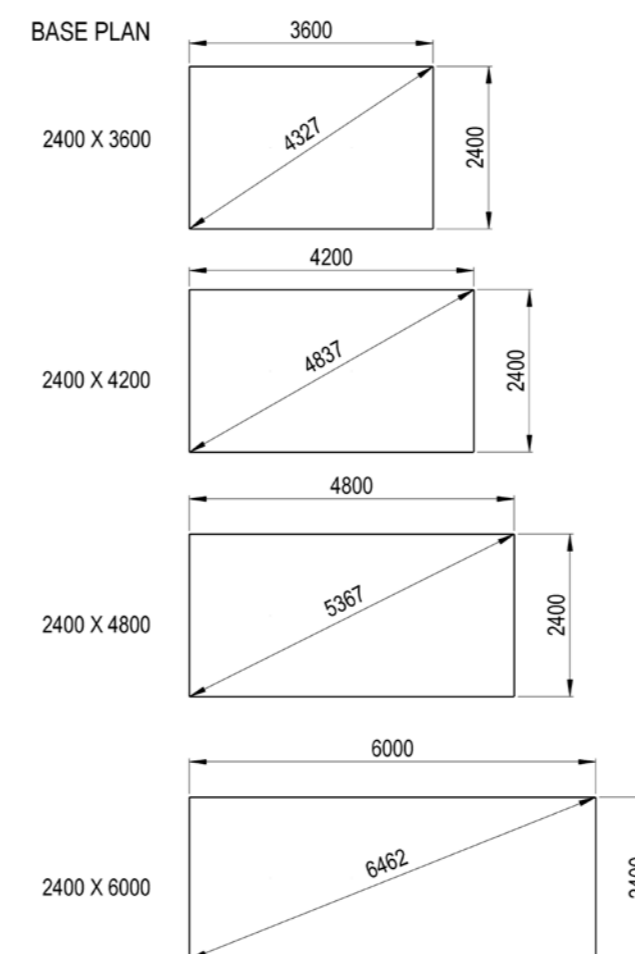

Base plan 3600mm projection

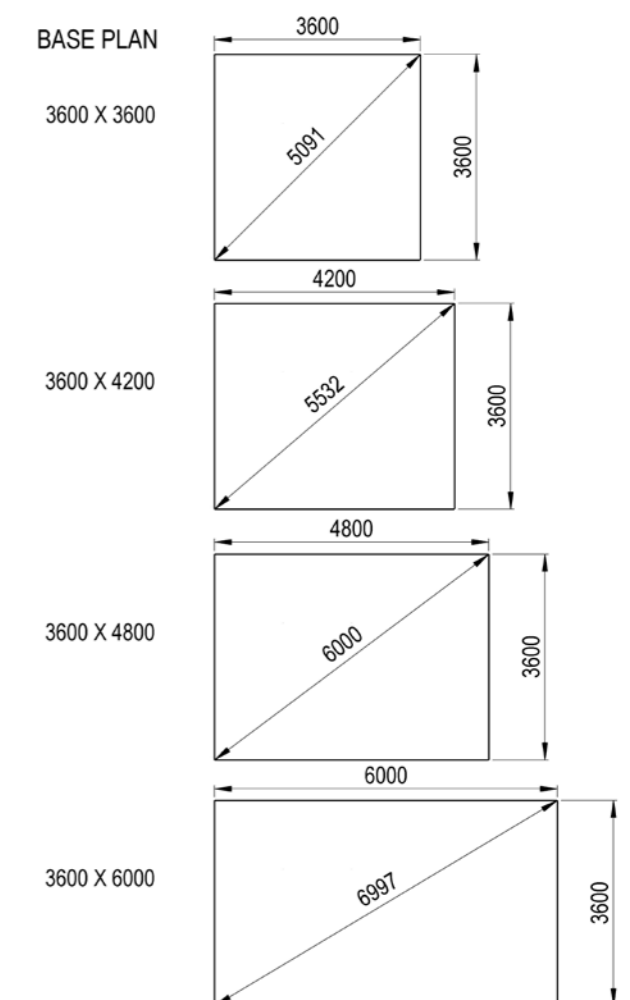

How to calculate your materials required?

To help you calculate the materials required for each job, we will provide details of critical dimension on your order confirmation.

In this section we have used the example of a Studio (2400mm x 3600mm with a bi-fold support beam) to demonstrate how you can calculate the other materials required to assemble the Garden Room. This page shows you the order confirmation and the following pages show you how to refer to the guide to build a materials list.

Order confirmation details: Right hand corner studio 2400 x 3600mm

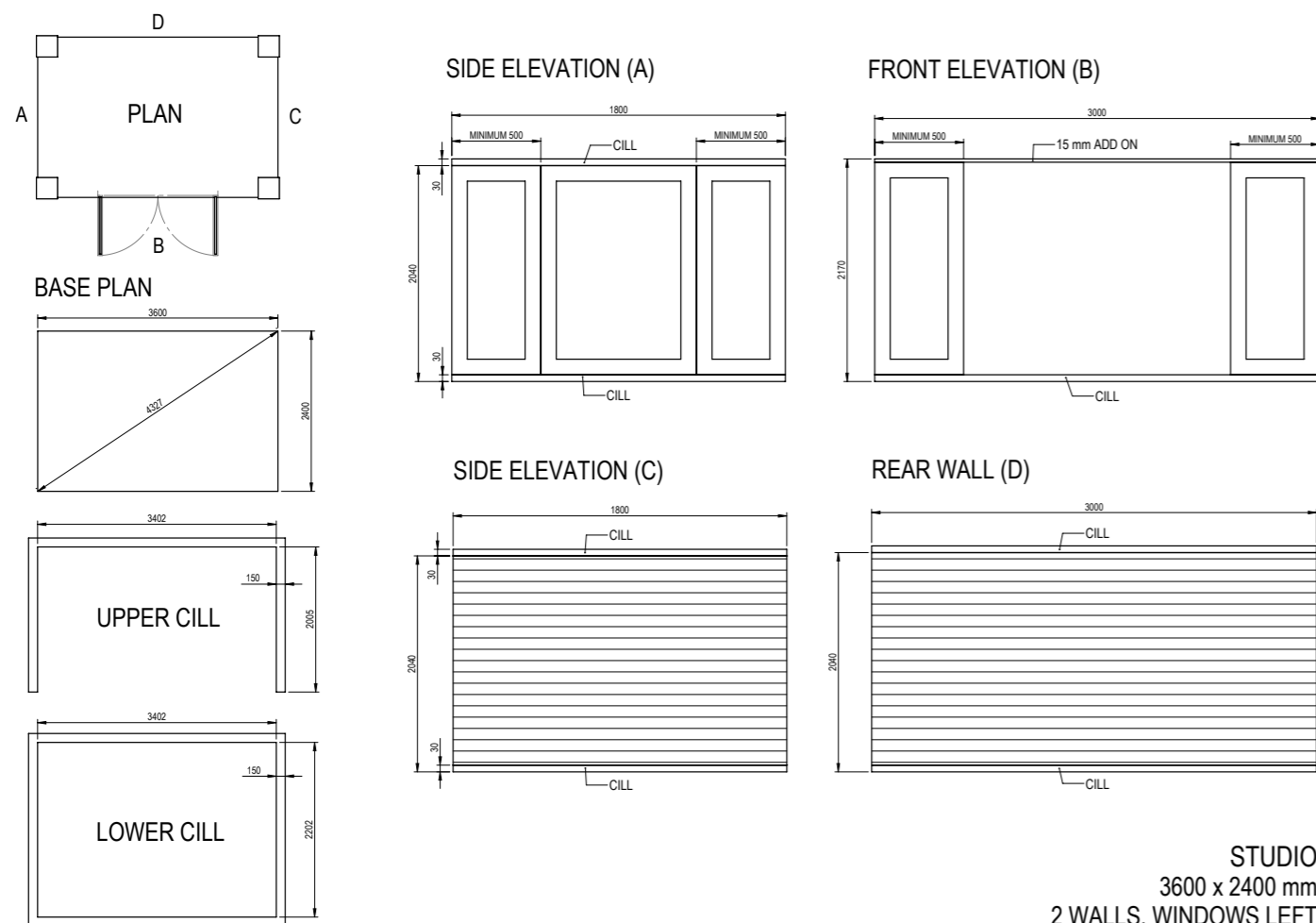

How to calculate your materials required?

How to calculate materials using this guide.

Base

The measurements below indicate the overall projection x width sizes from page 25. The diagonal check dimension to ensure that the base is square is also provided on the confirmation report. In this case 4327mm.

External Base Size

| | | | |
|-----------------|-----------------|-----------------|-----------------|
| 2400mm x 3600mm | 2400mm x 4200mm | 2400mm x 4800mm | 2400mm x 6000mm |
| 3600mm x 3600mm | 3600mm x 4200mm | 3600mm x 4800mm | 3600mm x 6000mm |

Cill

The cill measurements below use the internal width and internal projection calculations taken from the table on page 16. The recommended minimum cill is 150mm, however by using the internal frame dimension allows for slightly larger cills if required. For the Studio, there is an upper and lower cill. The upper cill is a 'C' shape on 3 sides of the structure. The total cill length required is 18.62m².

| Total Studio Cill Length Required (M) includes upper cill | | | | |
|---|-------|-------|-------|-------|
| | 3600 | 4200 | 4800 | 6000 |
| 2400 | 18.62 | 20.42 | 22.22 | 25.82 |
| 3600 | 23.42 | 25.22 | 27.02 | 30.62 |

Window & Door Apertures

To calculate the window apertures, chose your Garden Room projection and width from the left-hand columns of the table on page 20. To find out the required apertures for the different elevations, based on the Garden Room type, cross reference the size with type and elevation.

In this case the front elevation would be 3000mm wide and 2070 tall after deducting 70mm for the Eaves Support Beam and 30mm for the bottom cill. The side elevation would be 1800 wide and 2010 high after the 30mm deduction for the bottom cill.

| Projection | Width | The Studio | | | | The Tall Studio | | | | The Pavilion | | | | The Pavilion Premium |
|------------|-------|-----------------|-------|----------------|-------|-----------------|-------|----------------|-------|-----------------|-------|----------------|-------|------------------------------|
| | | Front Elevation | | Side Elevation | | Front Elevation | | Side Elevation | | Front Elevation | | Side Elevation | | Side Elevation |
| | | Height | Width | Height | Width | Height | Width | Height | Width | Height | Width | Height | Width | Width Between Inline Columns |
| 2400 | 3600 | 2170 | 3000 | 1800 | 2550 | 3000 | 2420 | 1800 | 2170 | 3000 | 2170 | 1800 | 750 | |
| | 4200 | | 3600 | | | 3600 | | | | | | | | |
| | 4800 | | 4200 | | | 4200 | | | | | | | | |
| | 6000 | | 5400 | | | 5400 | | | | | | | | |
| 3600 | 3600 | 2170 | 3000 | 3000 | 2550 | 3000 | 2369 | 3000 | 2170 | 3000 | 2170 | 3000 | 800 | |
| | 4200 | | 3600 | | | 3600 | | | | | | | | |
| | 4800 | | 4200 | | | 4200 | | | | | | | | |
| | 5400 | | 5400 | | | 5400 | | | | | | | | |

Please note: These values are total aperture sizes and do not include any deductions for frame add-ons on the lower cill. The Studios require an upper cill which sits above these apertures. Please note that when an eaves support beam is specified, a 70mm deduction is required off the front elevation frame height.

How to calculate your materials required?

Claddings

The external cladding area is 9.62m² shown in the table below. A waste factor will need to be added e.g with 10% waste factor it would be 10.56m².

The Studios

| Elevation Length | External Cladding Area on Each Elevation | | | | | |
|------------------|--|-----------|-----------|-----------------|-----------|-----------|
| | The Studio | | | The Tall Studio | | |
| | Width | 2400 proj | 3600 proj | Width | 2400 proj | 3600 proj |
| | Height | | | Height | | |
| 2400 | 1792 | 2010 | 1958 | 1792 | 2390 | 2338 |
| 3600 | 2992 | | | 2992 | | |
| 4200 | 3592 | | | 3592 | | |
| 4800 | 4192 | | | 4192 | | |
| 6000 | 5392 | | | 5392 | | |

The Pavilions

| Elevation Length | External Cladding Area | |
|------------------|------------------------|------------|
| | The Pavilion | |
| | Width | Height |
| 2400 | 1792 | 2400 Width |
| 3600 | 2992 | 2139 |
| 4200 | 3592 | |
| 4800 | 4192 | |
| 6000 | 5392 | |

Internal boardings

The table on page 18 shows that a total of 14.30m² of internal boarding is required for a right hand corner The Studio. A waste factor will need to be added e.g. with 10% waste it would be 15.73m².

The Studio

| | 3600 | 4200 | 4800 | 6000 |
|------|-------|-------|-------|-------|
| 2400 | 14.30 | 15.60 | 16.80 | 19.30 |
| 3600 | 23.23 | 25.23 | 27.13 | 31.13 |

ORDER FORM

Contact details:
partsales@ultraframe.co.uk OR 01200 452 906

ORDER

QUOTE

ACCOUNT No.

Company Name

Order Number

JOB REFERENCE

Company Contact

Telephone No.

Email

Delivery Address

.....

.....

POSTCODE

Delivery Date Req

Quotation Ref

Delivery To Site Req Yes No

HOW TO PLACE AN ORDER FOR GARDEN ROOM

LAYOUT

1. The Studio



2. The Tall Studio



3. The Pavilion



4. The Premium Pavilion



DESIGN

STUDIO Studio Tall Studio

PAVILION Pavilion Premium Pavilion

FIXED ROOFLIGHTS Yes No

If YES to fixed rooflights: Conservaglass Standard Blue Unglazed (24mm)

LAYOUT

Left Hand Corner with two solid walls

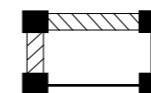

Right Hand Corner with two solid walls

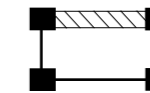

3 Walls



1 solid back wall and both sides with inline columns (Premium pavilion only)

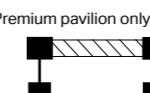

| KEY | |
|------------------------|--|
| Super-Insulated Column | |
| Walls | |
| Windows/ Doors | |
| Inline Column | |

SIZE

PROJECTION 2400mm 3600mm

WIDTH 3600mm 4200mm 4800mm 6000mm

COLOUR OF FRAMES (External/ Internal) Grey/Grey Grey/White

BI-FOLD SUPPORT BEAM REQUIRED (Only available for the front elevation) Yes No

STRUCTURAL GOALPOST REQUIRED Front Left Hand Side Right Hand Side

Job No.:3598

Please sign and return to
partsales@ultraframe.co.uk

SIGNED DATE

Gardenrooms

By Ultraframe

ultraframegardenrooms.com

Job No. 7085 Code: GRSG001 Garden Rooms Spec Guide 04/21

It is Ultraframe's policy to continually seek to improve its products, processes and services and we reserve the right to change specifications without prior notice.
We have been trading for over 35 years and strive to deliver unrivalled quality and service.